



ORIENT

Photo coupler

Product Data Sheet

Part Number: OR-341(B)

Customer: _____

Date: _____

一级代理商：

深圳市弗瑞鑫电子有限公司

地址：深圳市宝安区西乡大道302号金源商务大厦B座三楼

0 -
0 - 0 0

.frxelec.



%"

- (1) 3.0 A maximum peak output current
- (2) 2.5 A minimum peak output current
- (3) Rail-to-rail output voltage
- (4) 200 ns maximum propagation delay
- (5) 70 ns maximum propagation delay difference
- (6) LED current input with hysteresis
- (7) 20 kV/μs minimum Common Mode Rejection (CMR) at VCM = 1500 V
- (8) ICC = 3.0 mA maximum supply current
- (9) Under Voltage Lock-Out protection (UVLO) with hysteresis
- (10) Wide operating VCC Range: 15 to 30 V
- (11) Industrial temperature range: -40° C to 105° C
- (12) Safety approval
 - UL approved(No.E323844)
 - VDE approved(No.40029733)
 - CQC approved (No.CQC19001231480)
- (13) In compliance with RoHS, REACH standards
- (14) MSL Level 1

&"

The OR-341(B) contains an AlGaAs LED, which is optically coupled to an integrated circuit with a power output stage. This optocoupler is ideally suited for driving power IGBTs and MOSFETs used in motor control inverter applications. The high operating voltage range of the output stage provides the drive voltages required by gate controlled devices. The voltage and high peak output current supplied by this optocoupler make it ideally suited for direct driving IGBT with ratings up to 1200 V/ 100 A. For IGBTs with higher ratings, this optocoupler can be used to drive a discrete power stage which drives the IGBT gate.

▪"

- (1)IGBT/MOSFET gate drive (2)AC and Brushless DC motor drives
- (3)Renewable energy inverters (4)Industrial inverters (5)Switching power supplies

("

	VCC – VEE	VCC – VEE	VO
LED	“POSITIVE GOING”	“NEGATIVE GOING”	
	(i.e., TURN-ON)	(i.e., TURN-OFF)	
OFF	0		

Note: A 10 μF bypass capacitor must be connected between pins VCC and VEE.

)"

Input	Average Forward Input Current	I_F	25	mA
	Reverse Input Voltage	V_R	5	V
Output	“High” Peak Output Current	$I_{OH(PEAK)}$	3	A
	“Low” Peak Output Current	$I_{OL(PEAK)}$	3	A
	Output Collector Power Dissipation	P_O	700	mW
Total Power Dissipation		P_T	745	mW
Total Output Supply Voltage		$V_{CC} - V_{EE}$	35	V
Input Current (Rise/Fall Time)		$t_{r(IN)} / t_{f(IN)}$	500	ns
Insulation Voltage		V_{iso}	5000	Vrms
Working Temperature		T_{opr}	-40 + 105	
Storage Temperature		T_{stg}	-55 + 125	
*2 Soldering Temperature		T_{sol}	260	

*1. Room temperature = 25 . Exceeding the maximum absolute rating can permanently damage the device. Working long hours at the maximum absolute rating can affect reliability.

*2. soldering time is 10 seconds.

* "

Unless otherwise noted, all typical values are at TA = 25° C, VCC - VEE = 30 V, VEE = Ground; all minimum and maximum specifications are at recommended operating conditions (TA = -40 to 105° C, IF(ON) = 7 to 16 mA, VF(OFF) = -3.6 to 0.8 V, VEE = Ground, VCC = 15 to 30 V).

High Level Output Current	I _{OH}	-1.0	-2.3	—	A	V _O = (V _{CC} - 4V)
		-2.5	—	—		V _{CC} - V _O 15V
Low Level Output Current	I _{OL}	1.0	2.5	—	A	V _O = (V _{EE} + 2.5V)
		2.5	—	—		V _{CC} - V _O 15V
High Output Transistor RDS(ON)	R _{DS,OH}	—	1.7	3.0		I _{OH} = -2.5 A
Low Output Transistor RDS(ON)	R _{DS,OL}	—	0.8	1.8		I _{OH} = 2.5 A
High Level Output Voltage	V _{OH}	(V _{CC} - 0.3)	(V _{CC} - 0.2)	—	V	I _O = -100 mA
		—	V _{CC}	—	V	I _O = 0 mA, I _F = 10 mA
Low Level Output Voltage	V _{OL}	—	0.06	0.2	V	I _O = 100 mA
High Level Supply Current	I _{CCH}	—	1.51	3.0	mA	R _g =10 ,C _g = 25 nF, I _F =10 mA
Low Level Supply Current	I _{CCL}	—	1.65	3.0	mA	R _g =10 ,C _g =25nF, V _F =0 V
Threshold Input Current Low to High	I _{FLH}	—	1.89	4.0	mA	R _g =10 ,C _g =25nF, V _O >5 V
Threshold Input Voltage High to Low	V _{FHL}	0.8	—	—	V	
Input Forward Voltage	V _F	1.2	1.55	1.95	V	I _F = 10 mA
Temperature Coefficient of Forward Voltage	V _F / T _A	—	-1.7	—	mV/°C	I _F = 10 mA
Input Reverse Breakdown Voltage	B _{VR}	5	—	—	V	I _R = 100 μA
Input Capacitance	C _{IN}	—	70	—	pF	f = 1 MHz, V _F = 0V
UVLO Threshold	V _{UVLO+}	11.0	12.7	13.5	V	V _O > 5 V I _F = 10 mA
	V _{UVLO-}	9.5	11.2	12.0		
UVLO Hysteresis	U _{VLOHYS}	—	1.5	—		

+

Unless otherwise noted, all typical values are at TA = 25° C, VCC - VEE = 30 V, VEE = Ground; all minimum and maximum specifications are at recommended operating conditions (TA = -40 to 105° C, IF(ON) = 7 to 16 mA, VF(OFF) = -3.6 to 0.8 V, VEE = Ground, VCC = 15 to 30 V).

Propagation Delay Time to High Output Level	t _{PLH}	50	140	200	ns	R _g = 10 C _g = 25 nF f = 20 kHz Duty Cycle = 50% I _F = 7 mA to 16 mA V _{CC} = 15 V to 30 V
Propagation Delay Time to Low Output Level	t _{PHL}	50	140	200	ns	
Pulse Width Distortion	PWD	—	25	70	ns	
Propagation Delay Difference Between Any Two Parts	P _{DD} (t _{PHL} - t _{PLH})	-100	—	100	ns	
Rise Time	t _r	—	46	—	ns	V _{CC} = 30 V
Fall Time	t _f	—	43	—	ns	
Output High Level Common Mode Transient Immunity	CM _H	20	30	—	kV/μs	T _A = 25°C, I _F = 10mA V _{CC} = 30V, V _{CM} = 1500V with split resistors
Output Low Level Common Mode Transient Immunity	CM _L	20	30	—		T _A = 25°C, V _F = 0V, V _{CC} = 30V, V _{CM} = 1500V with split resistors

,

341= Part Number

(B)= Identification.

U = Lead form option, W or W1

Y = Tape and reel option (TA,TA1 or none).

Z = 'V' code for VDE safety (This options is not necessary).

* VDE Code can be selected.

S(TA)	Surface mount lead form (low profile) + TA tape & reel option	1000 units per reel
S(TA1)	Surface mount lead form (low profile) + TA1 tape & reel option	1000 units per reel

-"

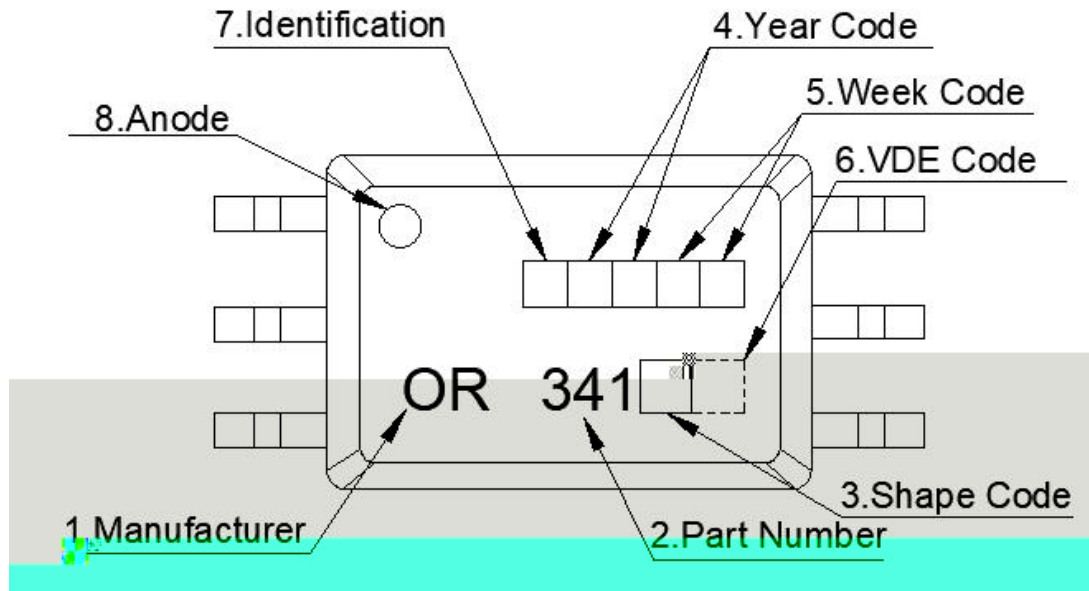

1. Manufacturer : ORIENT.
2. Part Number : 341.
3. Shape Code : Lead form option ,W or W1 .
4. Year Code '21' means '2021' and so on.
5. Week Code 01 means the first week, 02 means the second week and so on.
6. VDE Code . (Optional)
7. Identification.
8. Anode.

* VDE Mark can be selected.

%"

(1).OR-341(B)W

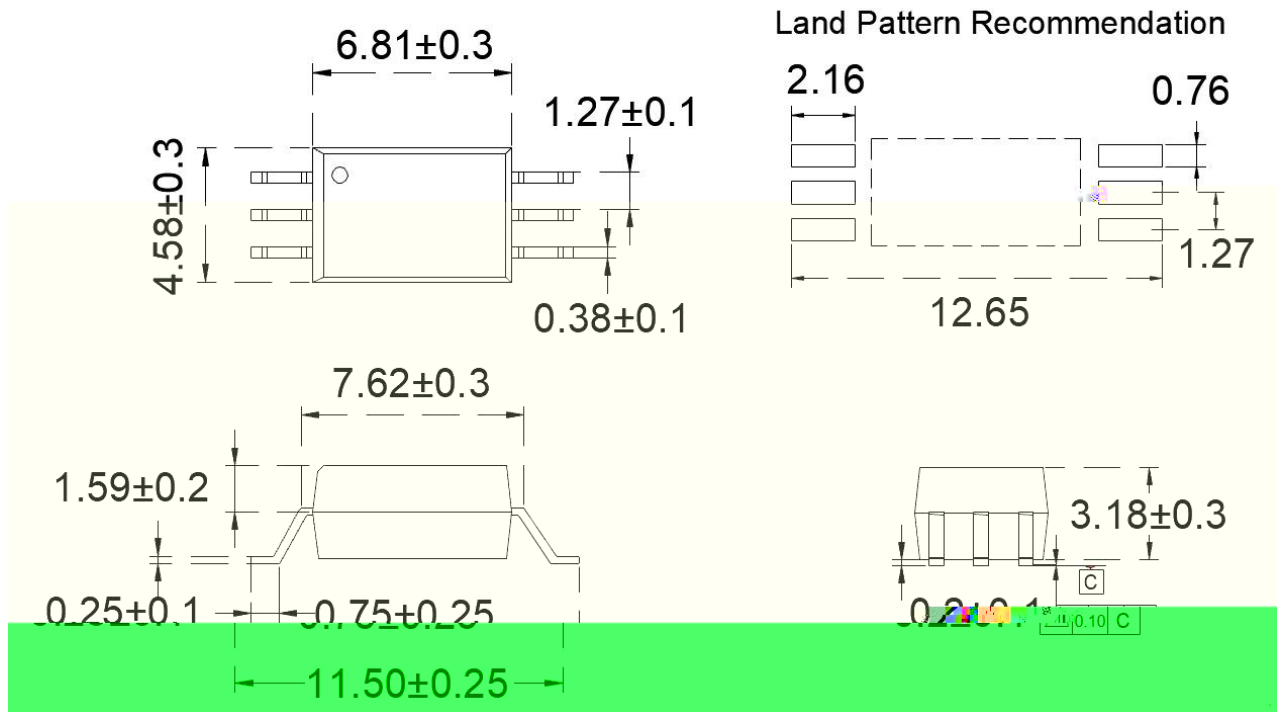

(2).OR-341(B)W1

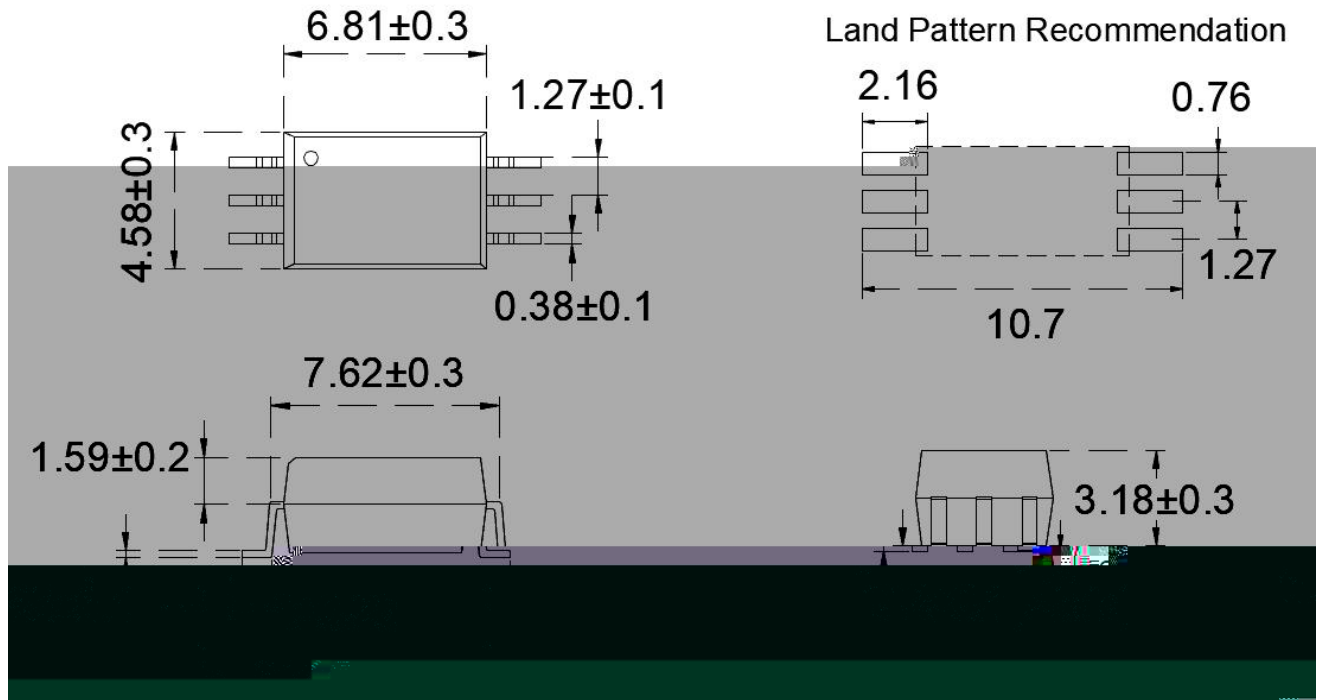

%%"

(1)OR-341(B)W-TA

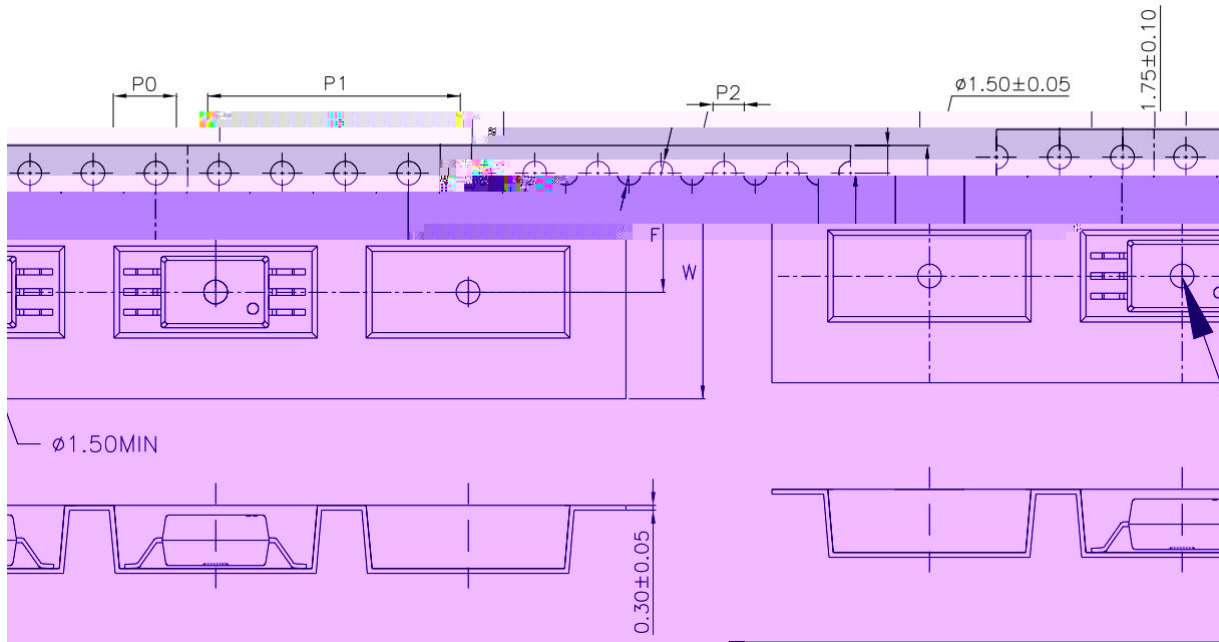

(2)OR-341(B)W-TA1

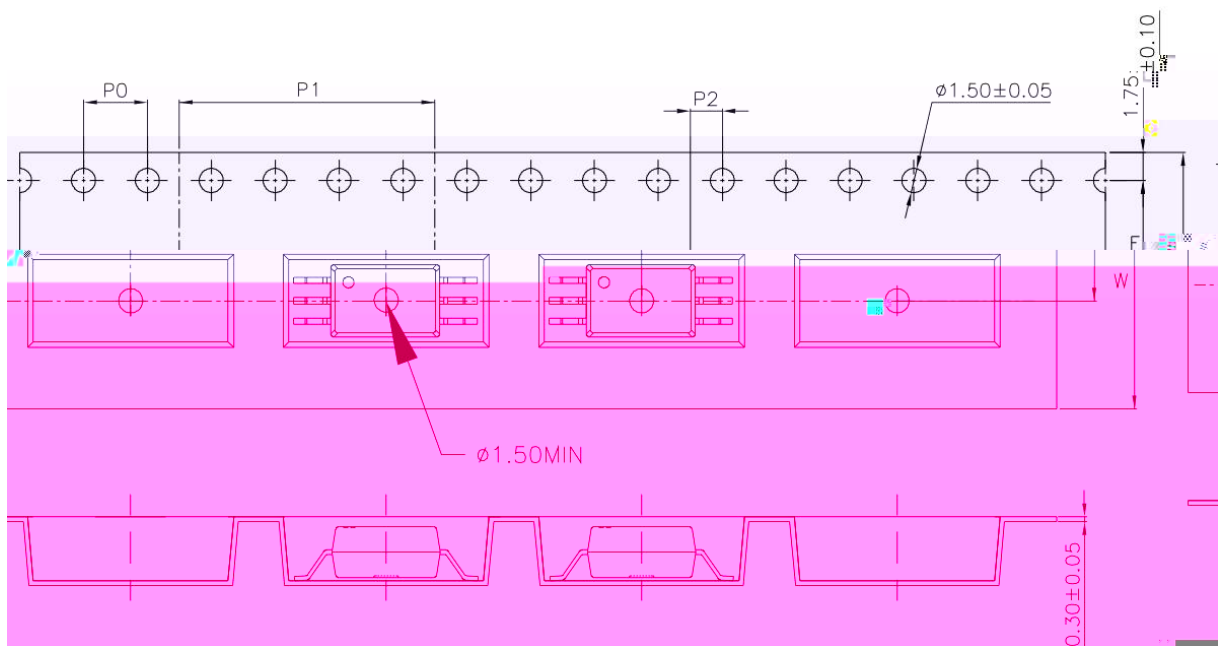

(1)OR-341(B)W1-TA

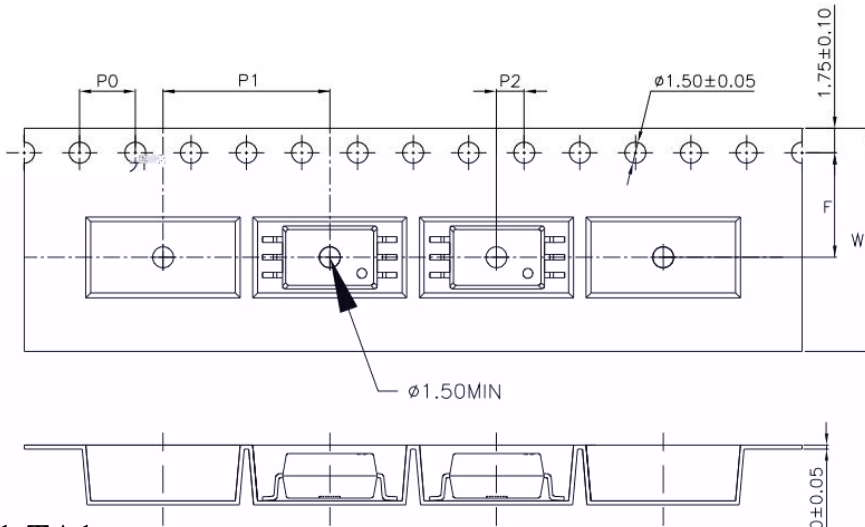

(2)OR-341(B)W1-TA1

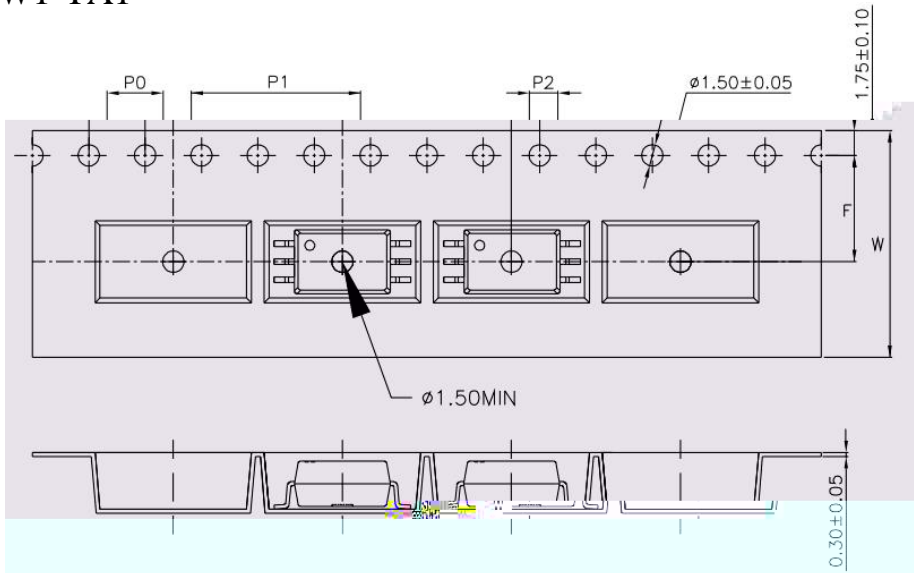

Type	symbol		
bandwidth	W	16 ± 0.3 (0.63)	16 ± 0.3 (0.63)
pitch	P0	4 ± 0.1 (0.16)	4 ± 0.1 (0.16)
pitch	F	7.5 ± 0.1 (0.3)	7.5 ± 0.1 (0.3)
	P2	2 ± 0.1 (0.079)	2 ± 0.1 (0.079)
interval	P1	16 ± 0.1 (0.63)	12 ± 0.1 (0.47)

Encapsulation type	TA/TA1
amount pcs	1000

%&"

Packing type	Reel type
Tape Width	16mm
Qty per Reel	1,000pcs
Small box (inner) Dimension	345*345*58.5mm
Large box (Outer) Dimension	620x360x360mm
Max qty per small box	2,000pcs
Max qty per large box	20,000pcs







Material Code: 120PCXXXXXX

P/N: OR-XXXXXX

Lot No.: XXXXXX-XXXX-TX-X

D/C: XXXX

Qty: XXXX PCS

“XXXXXXXXXXXXXXXXXX” (一体机序列码)

Made in China

内箱码 外箱码

1. Material Code :Product ID.
2. P/N :Contents with "Order Information" in the specification.
3. Lot No. :Product data.
4. D/C :Product weeks.
5. Quantity :Packaging quantity.



% " "

(1).IR Reflow soldering (JEDEC-STD-020C compliant)

One time soldering reflow is recommended within the condition of temperature and time profile shown below. Do not solder more than three times.

Preheat		
- Temperature Min (T Smin)		150°C
- Temperature Max (T Smax)		200°C
- Time (min to max) (ts)		90±30 sec
Soldering zone		
- Temperature (TL)		217°C
- Time (t L)		60 sec
Peak Temperature		260°C a q
Peak		

C

C 9f

www



% ("

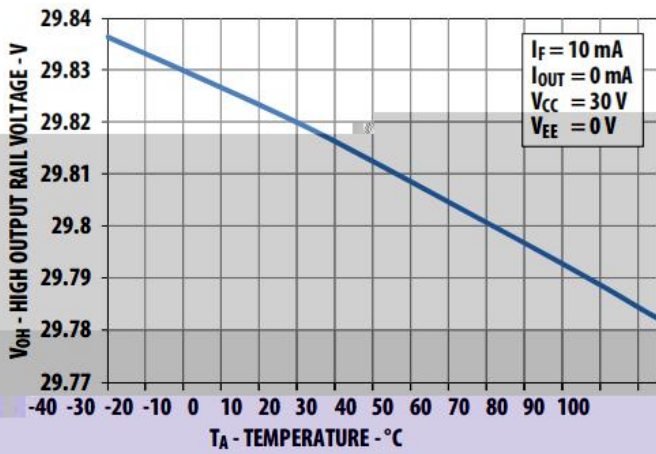

Figure 1. High output rail voltage vs. temperature

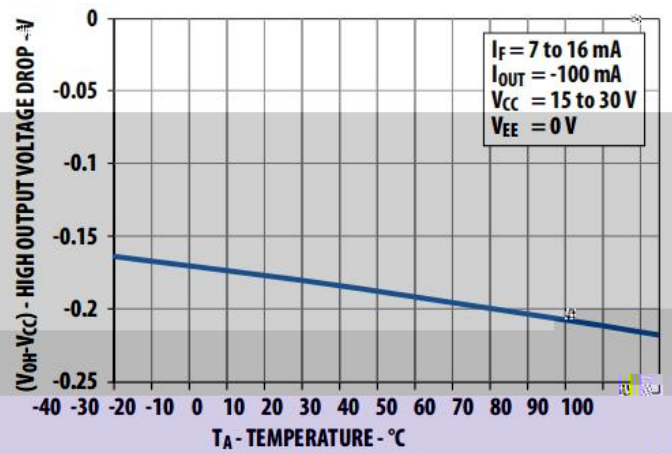

Figure 2. V_{OH} vs. temperature

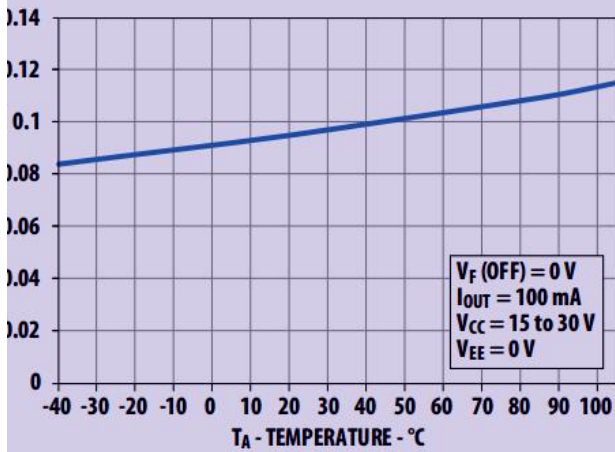

Figure 3. V_{OL} vs. temperature

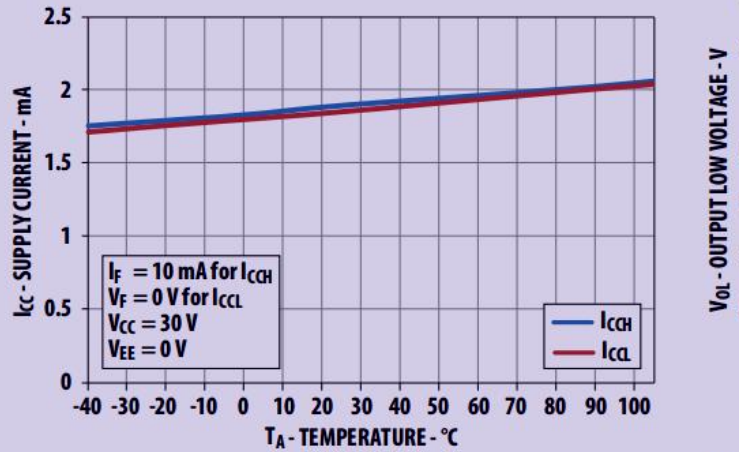
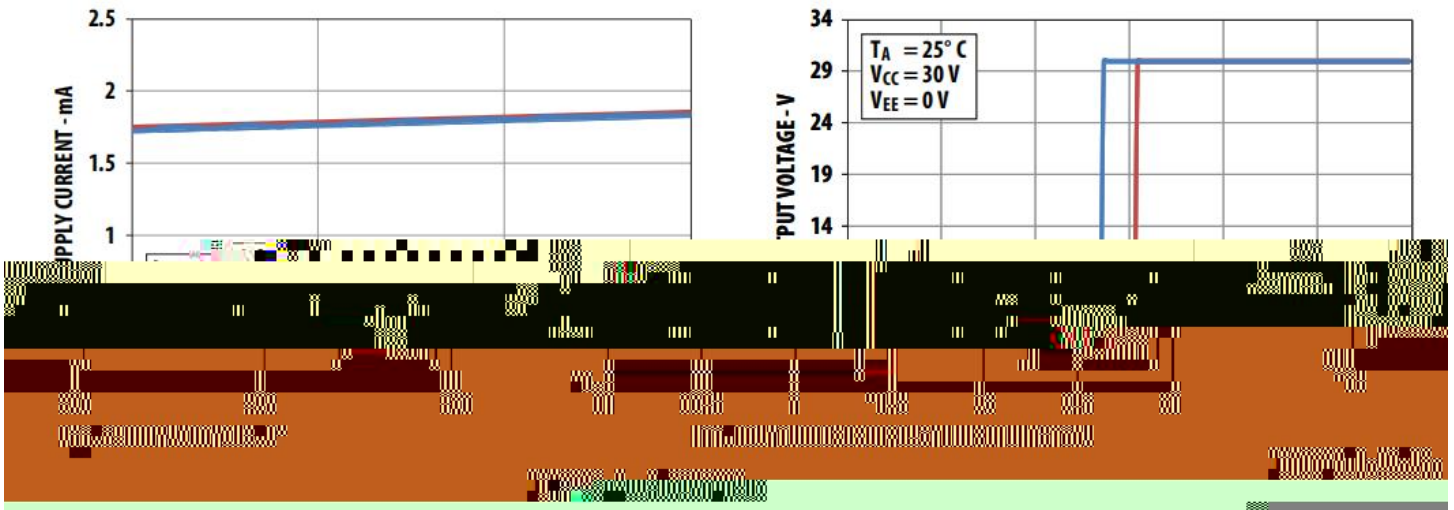

Figure 4. I_{CC} vs. temperature



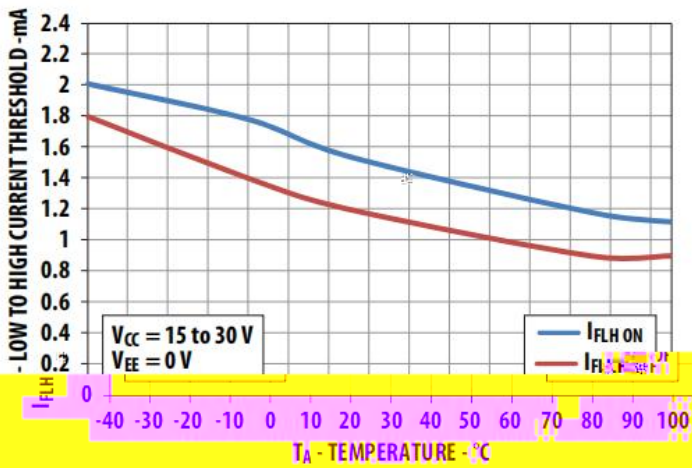

Figure 7. I_{FLH} vs. temperature

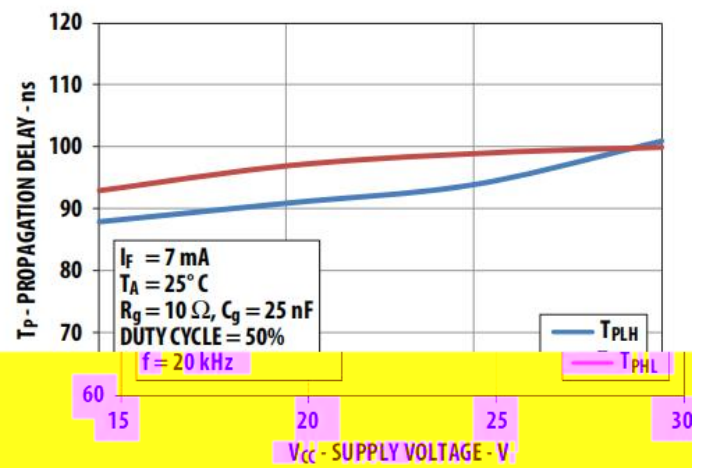

Figure 8. Propagation delays vs. V_{CC}

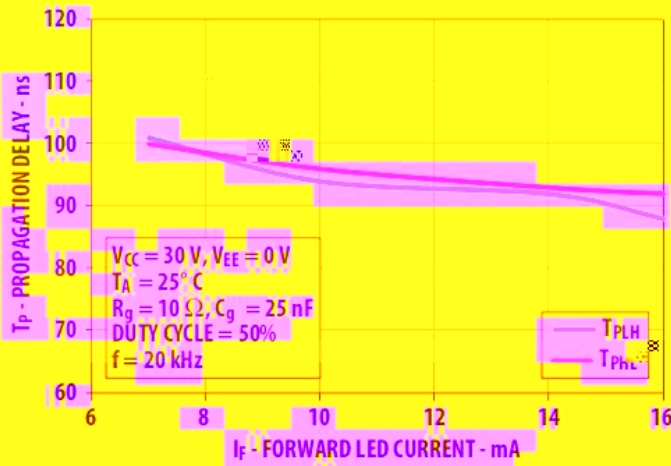

Figure 9. Propagation delays vs. I_F

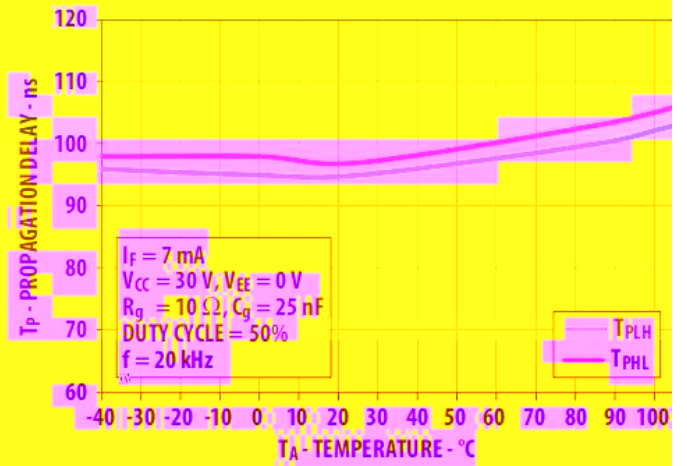

Figure 10. Propagation delays vs. temperature

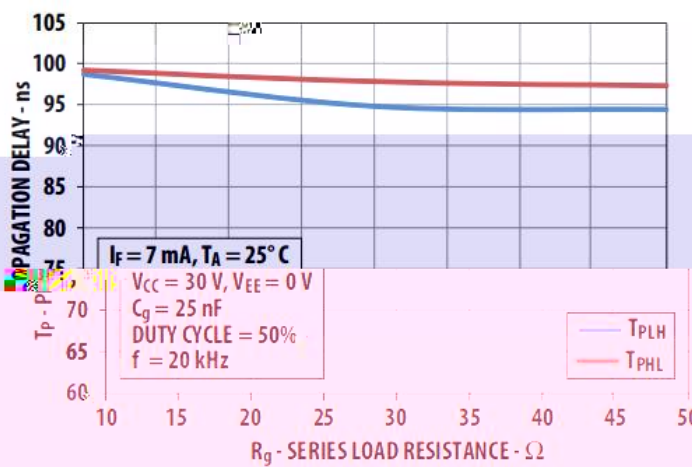

Figure 11. Propagation delay vs. R_g

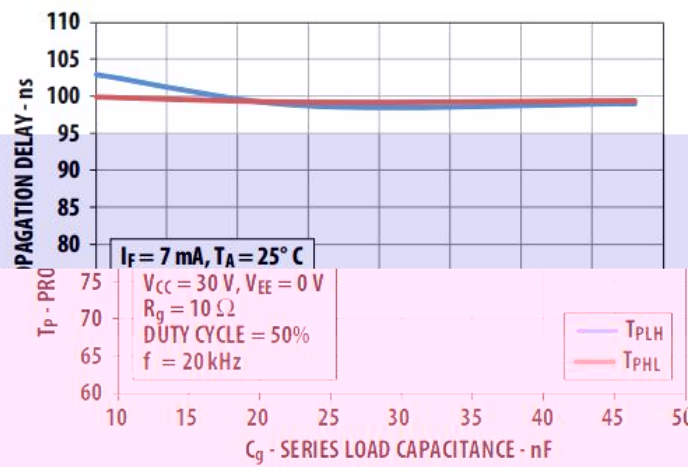

Figure 12. Propagation delay vs. C_g

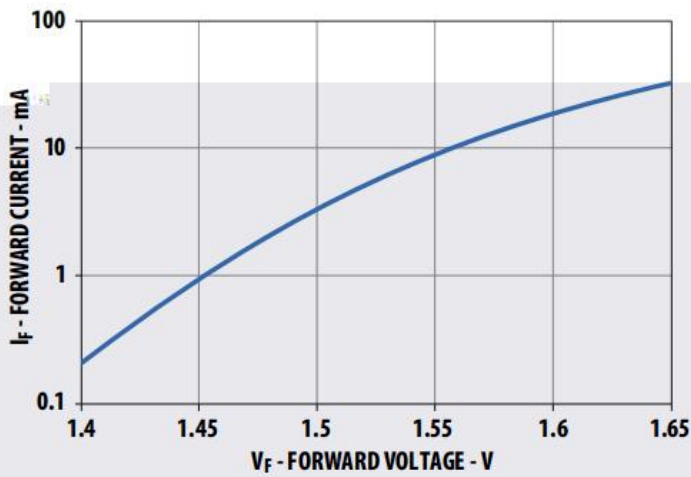

Figure 13. Input current vs. forward voltage

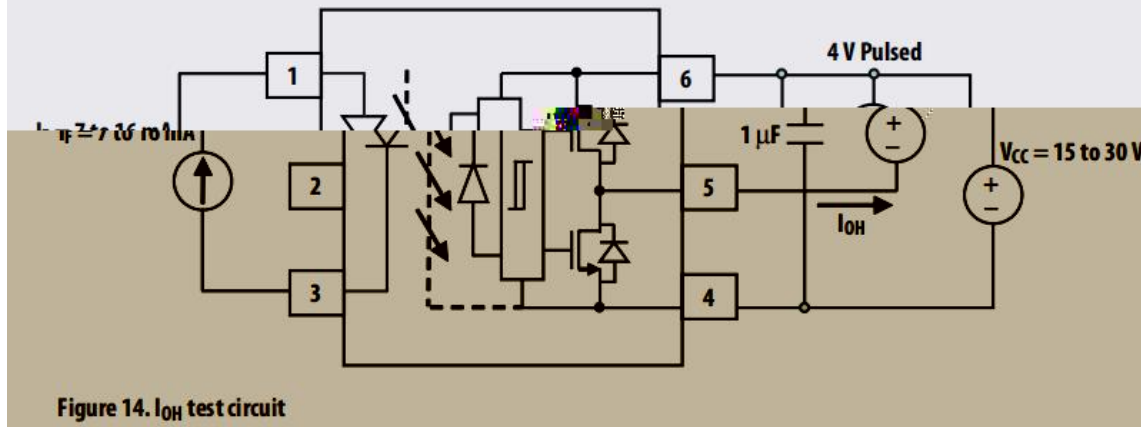

Figure 14. I_{OH} test circuit

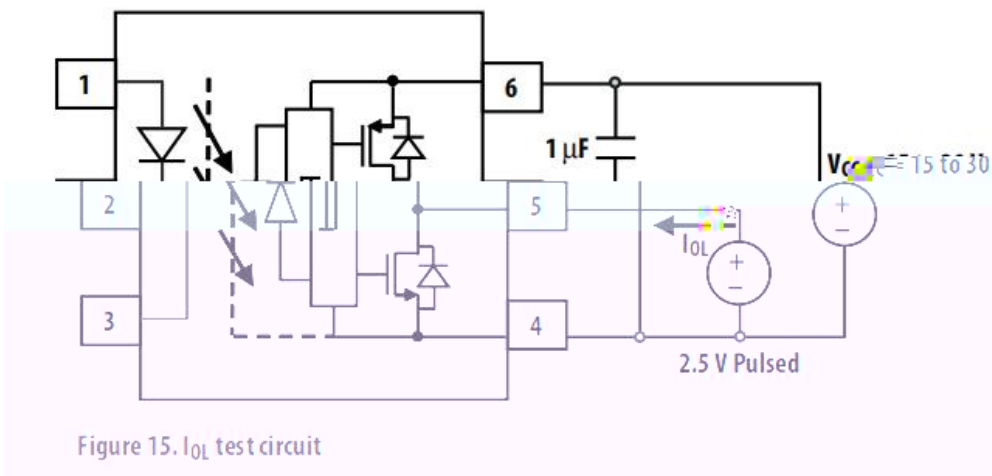
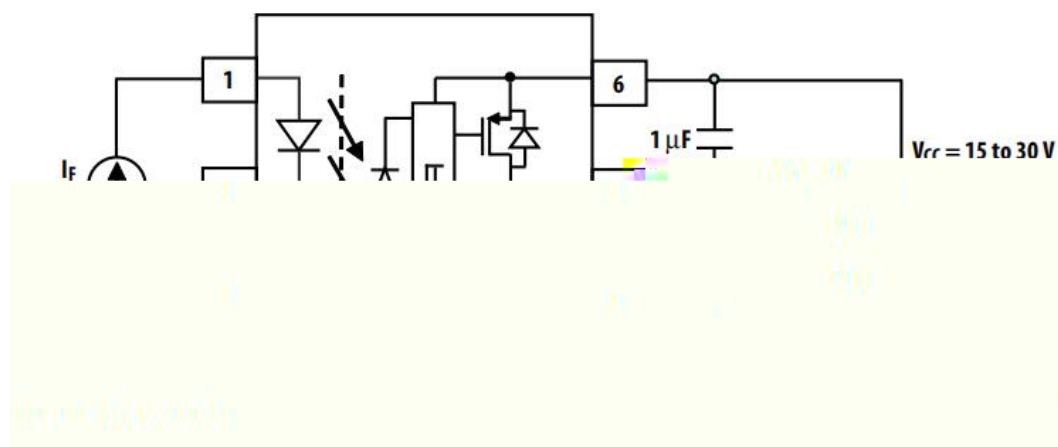
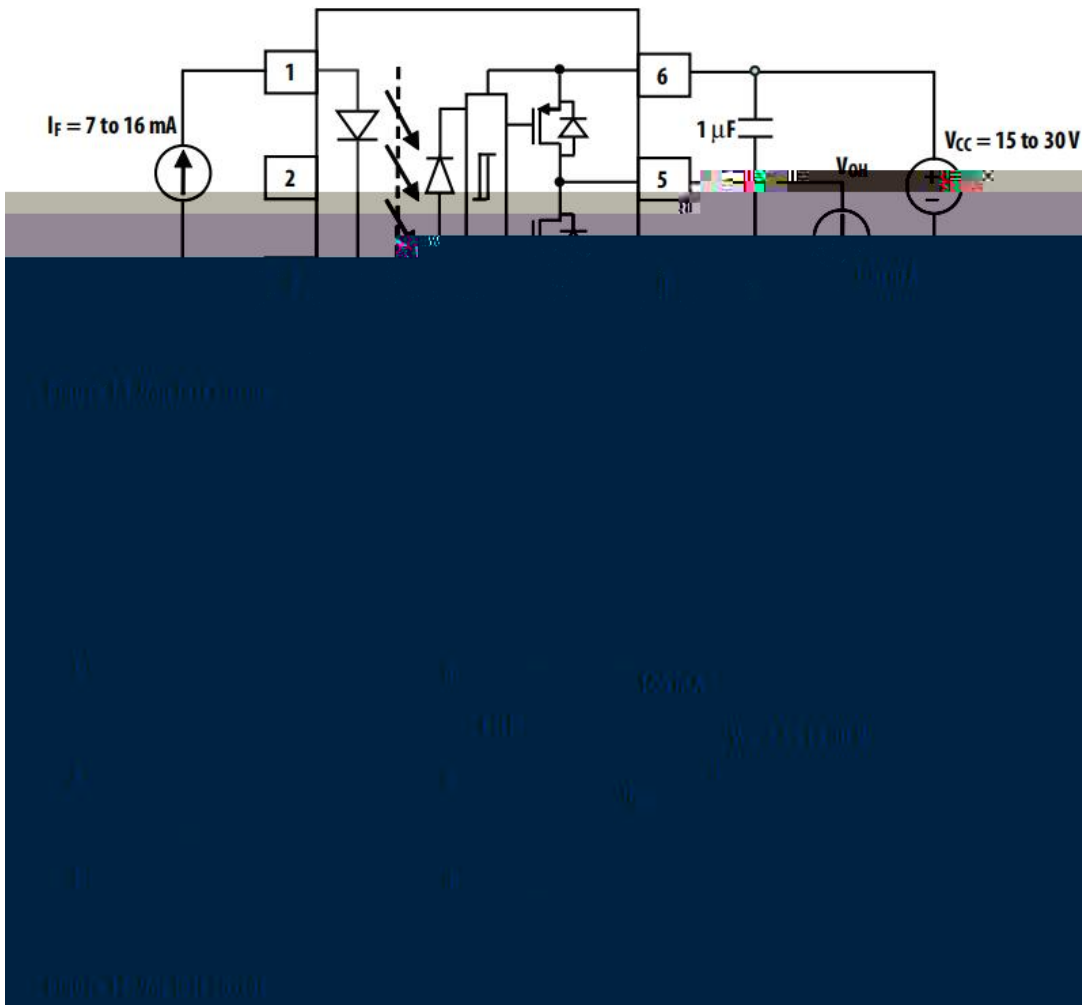
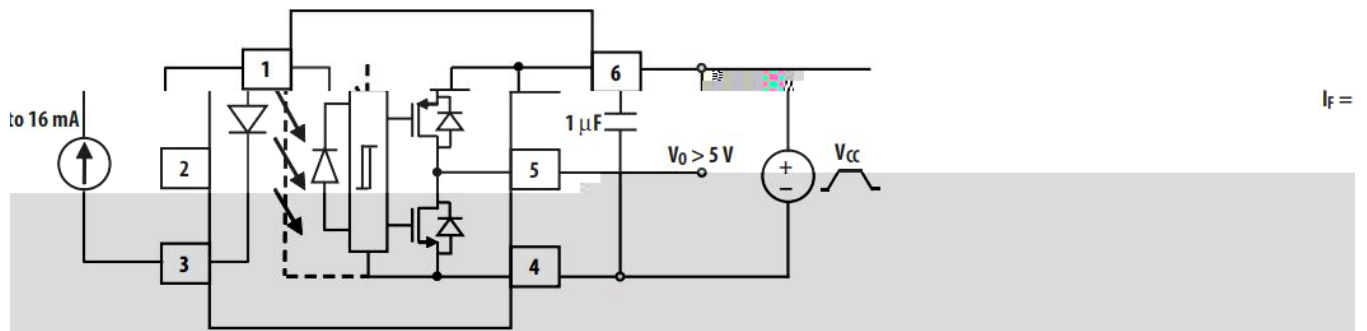

Figure 15. I_{OL} test circuit





19. UVLO test circuit

Fig

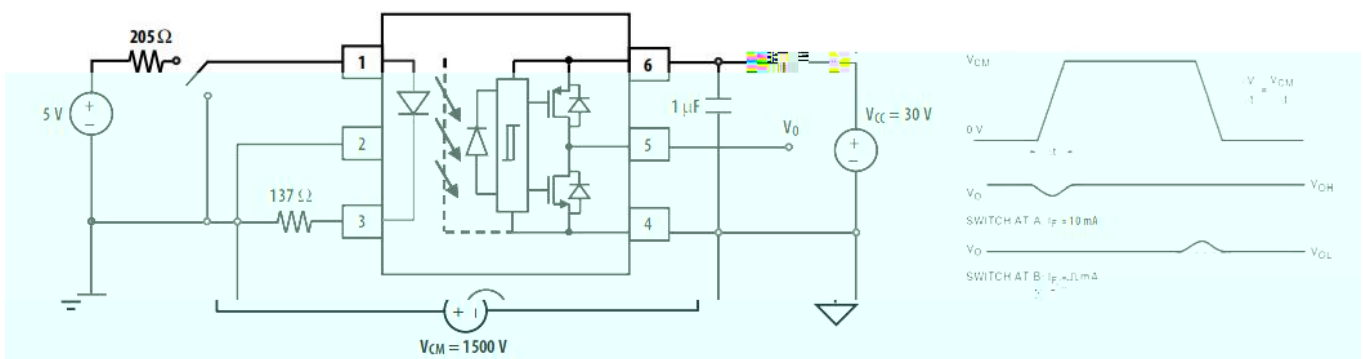
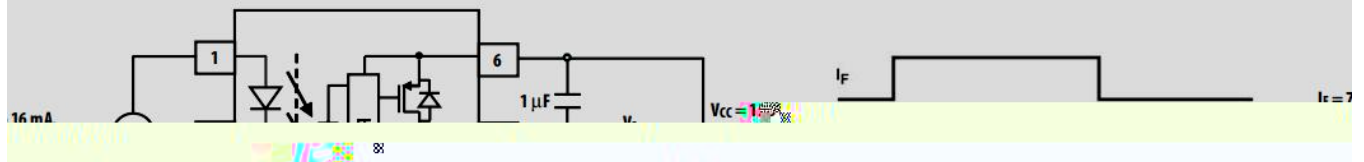

Figure 21. CMR test circuit with split resistors network and waveforms