



# MG50P12E2A

---

# MG50P12E2A

## ● IGBT- inverter

### Characteristic values

Parameter	Symbol	Conditions	Value			Unit	
			Min.	Typ.	Max.		
Gate-emitter Threshold Voltage	$V_{GE(th)}$	$V_{GE}=V_{CE}, I_C=1.7mA, T_{vj}=25$	5.2	5.8	6.4	V	
Collector-Emitter Cut-off Current	$I_{CES}$	$V_{CE}=1200V, V_{GE}=0V, T_{vj}=25$			1.0	mA	
Collector-Emitter Saturation Voltage	$V_{CE(sat)}$	$I_C=50A, V_{GE}=15V, T_{vj}=25$		1.90	2.30	V	
		$I_C=50A, V_{GE}=15V, T_{vj}=125$		2.20			
		$I_C=50A, V_{GE}=15V, T_{vj}=150$		2.30			
Gate Charge	$Q_G$			0.35		uC	
Input Capacitance	$C_{ies}$	$V_{CE}=25V, V_{GE}=0V,$ $f=1MHz, T_{vj}=25$		2.60		nF	
Reverse Transfer Capacitance	$C_{res}$			0.10		nF	
Internal Gate Resistance	$R_{gint}$			4.0			
Gate-Emitter leakage current	$I_{GES}$	$V_{CE}=0V, V_{GE}=20V, T_{vj}=25$			400	nA	
Turn-on Delay Time	$t_{d(on)}$	$I_C=50A$ $V_{CE}=600V$ $V_{GE}=\pm 15V$ $R_G=15\Omega$ $T_{vj}=25$		168		ns	
Rise Time	$t_r$			34		ns	
Turn-off Delay Time	$t_{d(off)}$				320		ns
Fall Time	$t_f$				78		ns
Energy Dissipation During Turn-on Time	$E_{on}$				5.42		mJ
Energy Dissipation During Turn-off Time	$E_{off}$				4.15		mJ
Turn-on Delay Time	$t_{d(on)}$		$I_C=50A$ $V_{CE}=600V$ $V_{GE}=\pm 15V$ $R_G=15\Omega$ $T_{vj}=125$		175		ns
Rise Time	$t_r$			42		ns	
Turn-off Delay Time	$t_{d(off)}$				426		ns
Fall Time	$t_f$				148		ns
Energy Dissipation During Turn-on Time	$E_{on}$				7.26		mJ
Energy Dissipation During Turn-off Time	$E_{off}$				5.80		mJ
SC Data	$I_{sc}$	$T_p \leq 10\mu s, V_{GE}=15V, T_{vj}=150$ , $V_{cc}=900V, V_{CEM} \leq 1200V$			220		A

# MG50P12E2A

## ● Diode-inverter

### Absolute Maximum Ratings

Parameter	Symbol	Conditions	Value	Unit
Repetitive Peak Reverse Voltage	$V_{RRM}$	$T_{vj}=25$	1200	V
Continuous DC Forward Current	$I_F$		50	A
Repetitive Peak Forward Current	$I_{FRM}$	$t_p=1\text{ms}$	100	A
$I^2t$ -value	$I^2t$	$V_R=0, t_p=10\text{ms}, T_{vj}=125$	560	A <sup>2</sup> s
		$V_R=0, t_p=10\text{ms}, T_{vj}=150$	480	

### Characteristic values

Parameter	Symbol	Conditions	Value			Unit
			Min.	Typ.	Max.	
Forward Voltage	$V_F$	$I_F=50\text{A}, T_{vj}=25$		1.90	2.40	V
		$I_F=50\text{A}, T_{vj}=125$		1.90		
		$I_F=50\text{A}, T_{vj}=150$		1.95		
Recovered Charge	$Q_{rr}$	$I_F=50\text{A}$		5.8		uC
Peak Reverse Recovery Current	$I_{rr}$	$V_R=600\text{V}$ $-di_F/dt=1500\text{A/us}$		56		A
Reverse Recovery Energy	$E_{rec}$	$T_{vj}=25$		1.85		mJ
Recovered Charge	$Q_{rr}$	$I_F=50\text{A}$		9.1		uC
Peak Reverse Recovery Current	$I_{rr}$	$V_R=600\text{V}$ $-di_F/dt=1500\text{A/us}$		58		A
Reverse Recovery Energy	$E_{rec}$	$T_{vj}=125$		3.30		mJ

# MG50P12E2A

## ● IGBT-brake-chopper Absolute Maximum Ratings

Parameter	Symbol	Conditions	Value	Unit
Collector-Emitter Voltage	$V_{CES}$	$V_{GE}=0V, I_C=1mA, T_{vj}=25$	1200	V
Continuous Collector Current	$I_C$	$T_c=100$ $v_{jmax}$ 175	35	A
Repetitive Peak Collector Current	$I_{CRM}$	$t_p=1ms$	70	A
Gate-Emitter Voltage	$V_{GES}$	$T_{vj}=25$	20	V
Total Power Dissipation	$P_{tot}$	$T_c=25$ $T_{vjmax}=175$	227	W

## Characteristic values

Parameter	Symbol	Conditions	Value			Unit	
			Min.	Typ.	Max.		
Gate-emitter Threshold Voltage	$V_{GE(th)}$	$V_{GE}=V_{CE}, I_C=1.4mA, T_{vj}=25$	5.2	5.8	6.4	V	
Collector-Emitter Cut-off Current	$I_{CES}$	$V_{CE}=1200V, V_{GE}=0V, T_{vj}=25$			1.0	mA	
Collector-Emitter Saturation Voltage	$V_{CE(sat)}$	$I_C=35A, V_{GE}=15V, T_{vj}=25$		1.85	2.25	V	
		$I_C=35A, V_{GE}=15V, T_{vj}=125$		2.15			
		$I_C=35A, V_{GE}=15V, T_{vj}=150$		2.25			
Gate Charge	$Q_G$			0.27		uC	
Input Capacitance	$C_{ies}$	$V_{CE}=25V, V_{GE}=0V,$ $f=1MHz, T_{vj}=25$		2.00		nF	
Reverse Transfer Capacitance	$C_{res}$			0.07		nF	
Gate-Emitter leakage current	$I_{GES}$	$V_{CE}=0V, V_{GE}=20V, T_{vj}=25$			400	nA	
Turn-on Delay Time	$t_{d(on)}$	$I_C=35A$ $V_{CE}=600V$ $V_{GE}=\pm 15V$ $R_G=12\Omega$ $T_{vj}=25$		25		ns	
Rise Time	$t_r$			13		ns	
Turn-off Delay Time	$t_{d(off)}$			24		ns	
Fall Time	$t_f$			115		ns	
Energy Dissipation During Turn-on Time	$E_{on}$				1.90		mJ
Energy Dissipation During Turn-off Time	$E_{off}$				2.00		mJ

# MG50P12E2A

Turn-on Delay Time	$t_{d(on)}$	$I_C = 35\text{ A}$ $V_{CE} = 600\text{ V}$ $V_{GE} = \pm 15\text{ V}$ $R_G = 12\Omega$ $T_{vj} = 125$	25	ns
Rise Time	$t_r$		16	ns
Turn-off Delay Time	$t_{d(off)}$		295	ns
Fall Time	$t_f$		170	ns
Energy Dissipation During Turn-on Time	$E_{on}$		2.90	mJ
Energy Dissipation During Turn-off Time	$E_{off}$		2.90	mJ
SC Data	$I_{sc}$		$T_p \leq 10\mu\text{s}, V_{GE} = 15\text{ V}, T_{vj} = 150$ , $V_{cc} = 900\text{ V}, V_{CEM} \leq 1200\text{ V}$	150

## ● Diode-Brake-Chopper

### Absolute Maximum Ratings

Parameter	Symbol	Conditions	Value	Unit
Repetitive Peak Reverse Voltage	$V_{RRM}$	$T_j = 25$	1200	V
Continuous DC Forward Current	$I_F$		15	A
Repetitive Peak Forward Current	$I_{FRM}$	$t_p = 1\text{ ms}$	30	A
$I^2t$ -value	$I^2t$	$V_R = 0, t_p = 10\text{ ms}, T_j = 125$	16.0	A <sup>2</sup> s
		$V_R = 0, t_p = 10\text{ ms}, T_j = 150$	14.0	

### Characteristic values

Parameter	Symbol	Conditions	Value			Unit
			Min.	Typ.	Max.	
Forward Voltage	$V_F$	$I_F = 15\text{ A}, T_{vj} = 25$		2.00	2.40	V
		$I_F = 15\text{ A}, T_{vj} = 125$		2.10		
		$I_F = 15\text{ A}, T_{vj} = 150$		2.10		
Recovered Charge	$Q_{rr}$	$I_F = 15\text{ A}$		1.10		uC
Peak Reverse Recovery Current	$I_{rr}$	$V_R = 600\text{ V}$ $-di_F/dt = 550\text{ A}/\mu\text{s}$		12.0		A
Reverse Recovery Energy	$E_{rec}$	$T_{vj} = 25$		0.30		mJ
Recovered Charge	$Q_{rr}$	$I_F = 15\text{ A}$		1.90		uC
Peak Reverse Recovery Current	$I_{rr}$	$V_R = 600\text{ V}$ $-di_F/dt = 550\text{ A}/\mu\text{s}$		14.0		A
Reverse Recovery Energy	$E_{rec}$	$T_{vj} = 125$		0.60		mJ



# MG50P12E2A

## ● Diode-Rectifier

### Absolute Maximum Ratings

Parameter	Symbol	Conditions	Value	Unit
Repetitive Peak Reverse Voltage	$V_{RRM}$	$T_j=25$	1600	V
Average output Current 50/60Hz, sine wave	$I_{F(AV)}$	$T_c=100$	65	A
Maximum RMS Current at Rectifier Output	$I_{RMSM}$	$T_c=100$	110	A
Surge Forward Current	$I_{FSM}$	$V_R=0, t_p=10ms, T_j=45$	850	A
$I^2t$ -value	$I^2t$	$V_R=0, t_p=10ms, T_j=45$	3610	A <sup>2</sup> s

### Characteristic values

Parameter	Symbol	Conditions	Value			Unit
			Min.	Typ.	Max.	
Diode Forward Voltage	$V_F$	$I_F=50A, T_j=125$		1.0		V
Reverse Current	$I_R$	$T_j=125, V_R=1600V$			1.5	mA

## ● NTC-Thermistor

### Characteristic values

Parameter	Symbol	Conditions	Value			Unit
			Min.	Typ.	Max.	
Rated Resistance	$R_{25}$			5.0		k
Deviation of R100	R/R	$T_c=100, R_{100}=493.3$	-5		5	%
Power Dissipation	$P_{25}$				20.0	mW
B-value	$B_{25/50}$	$R_2=R_{25}\exp[B_{25/50}(1/T_2-1/(298.15 K))]$		3375		K



# MG50P12E2A

---



# MG50P12E2A

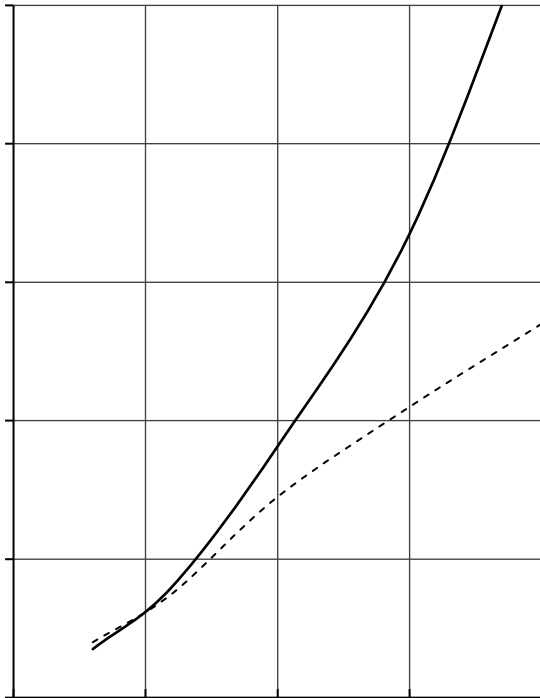
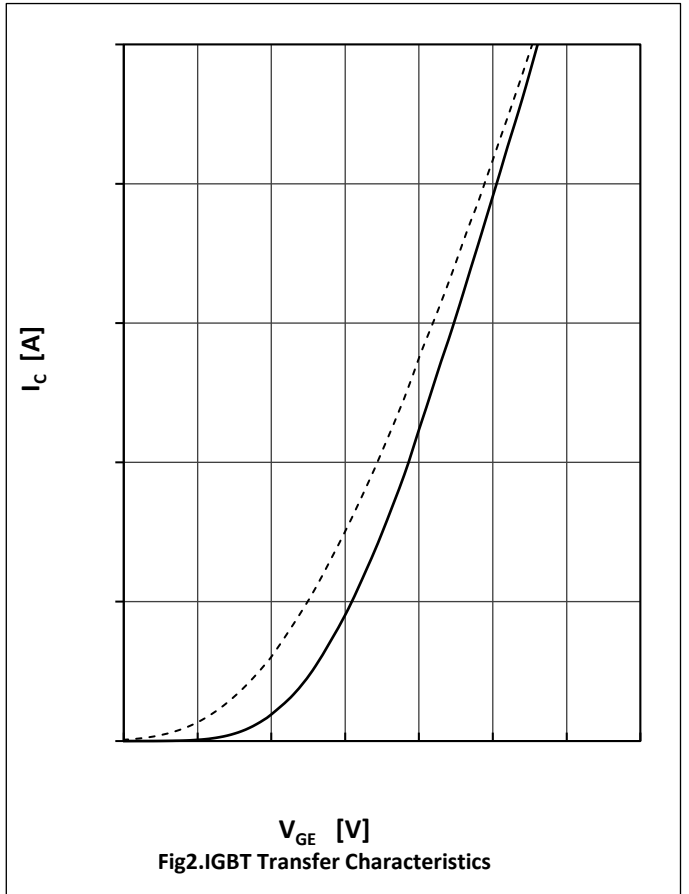
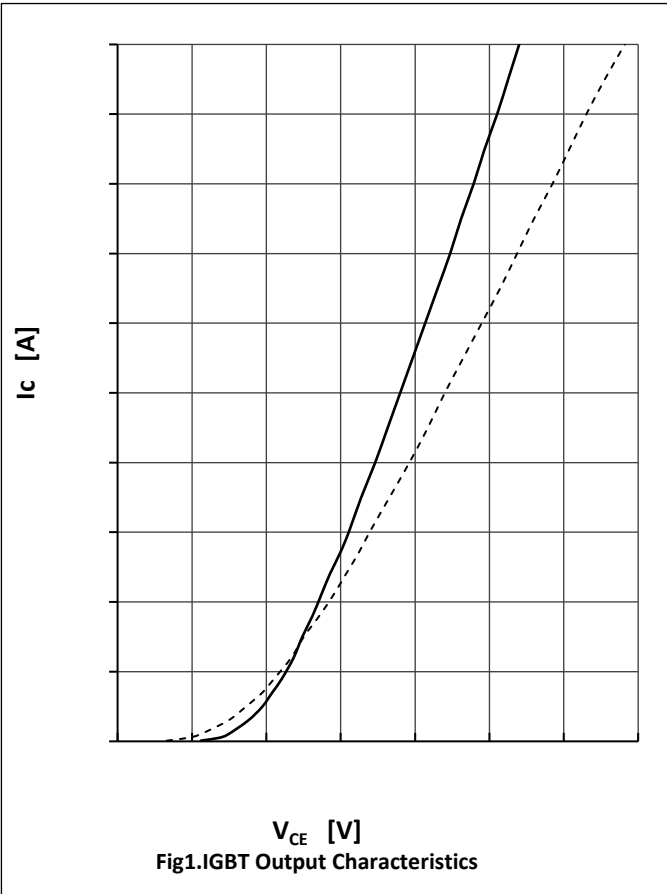





# MG50P12E2A

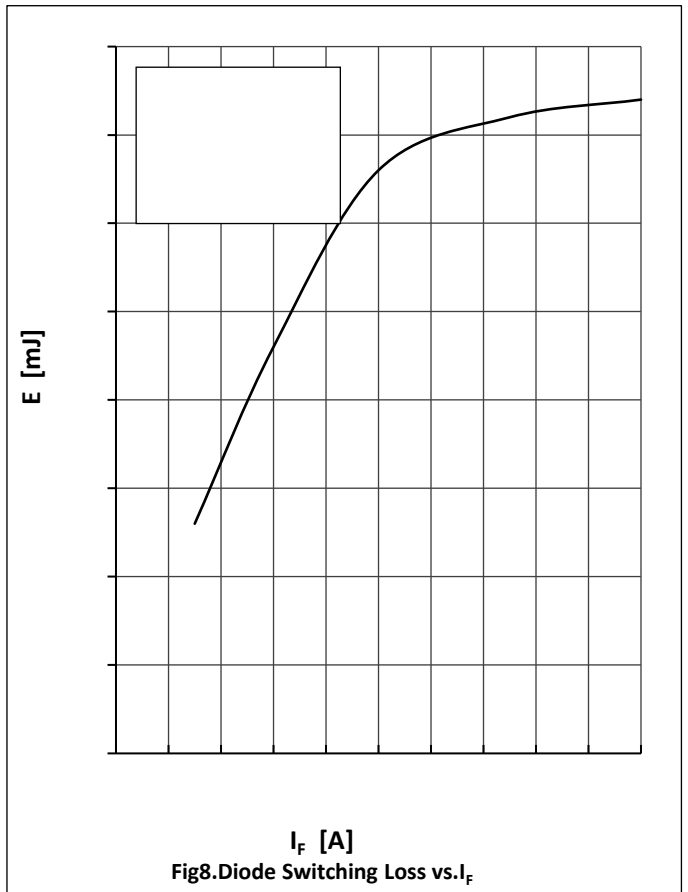
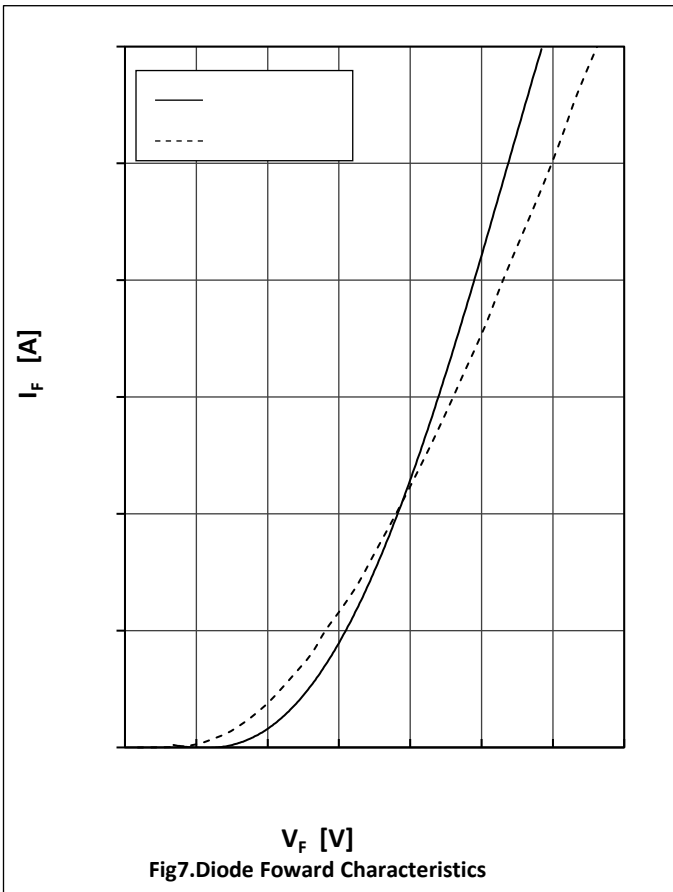
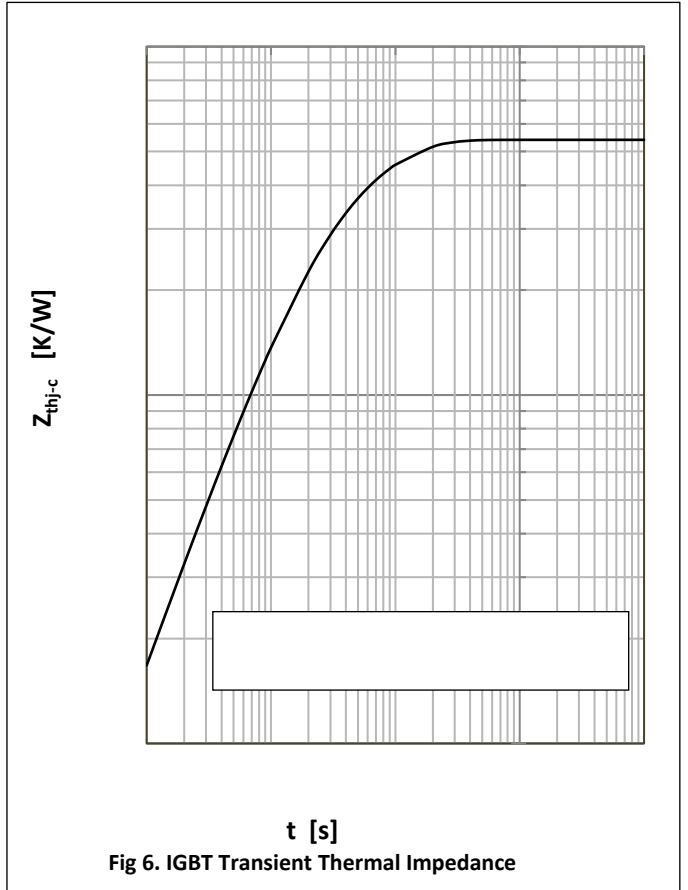
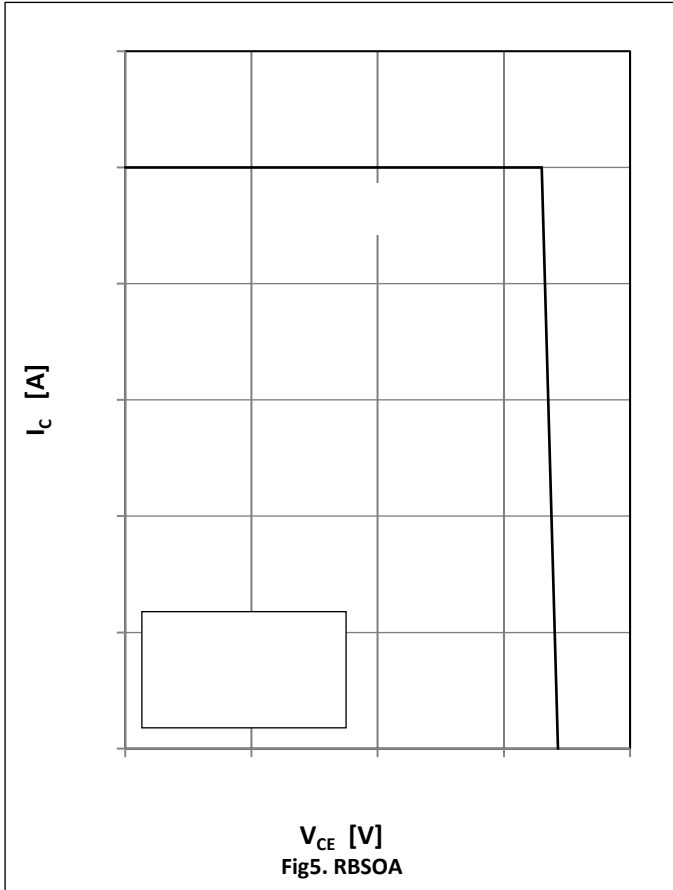



# MG50P12E2A

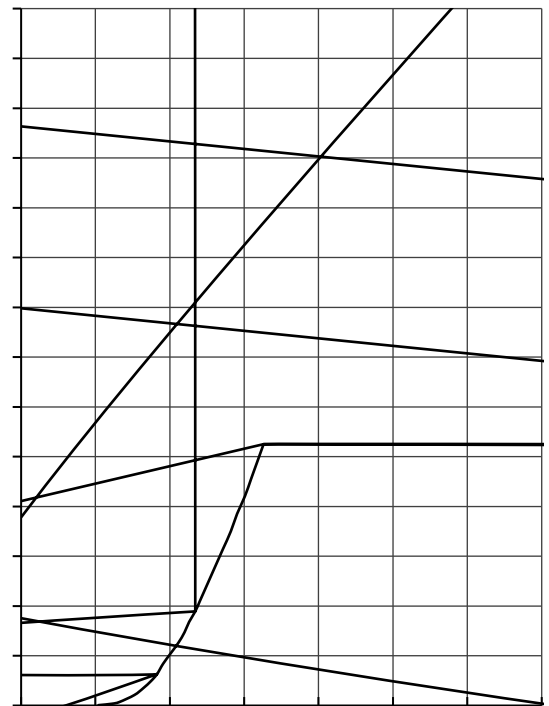
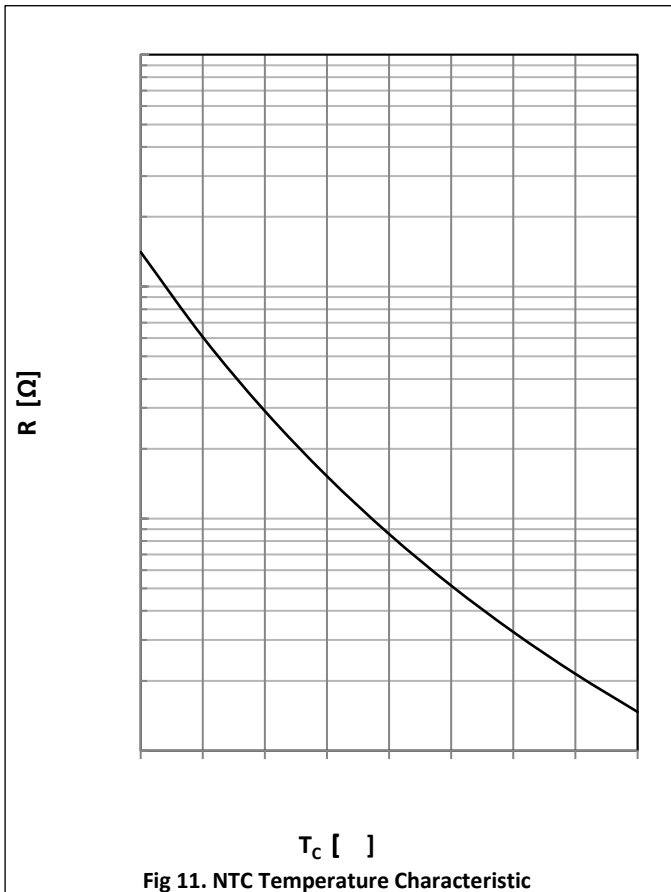
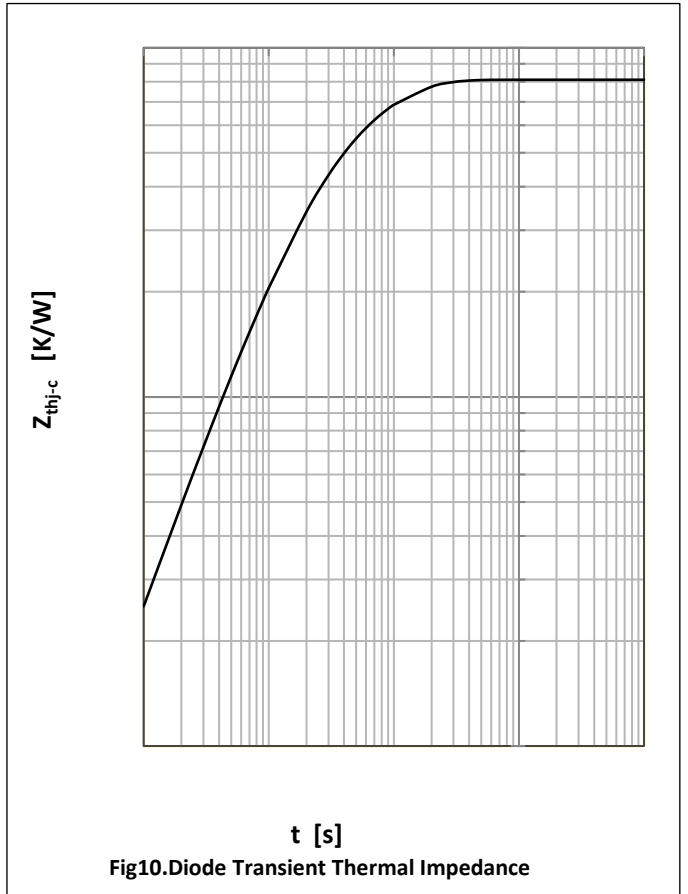
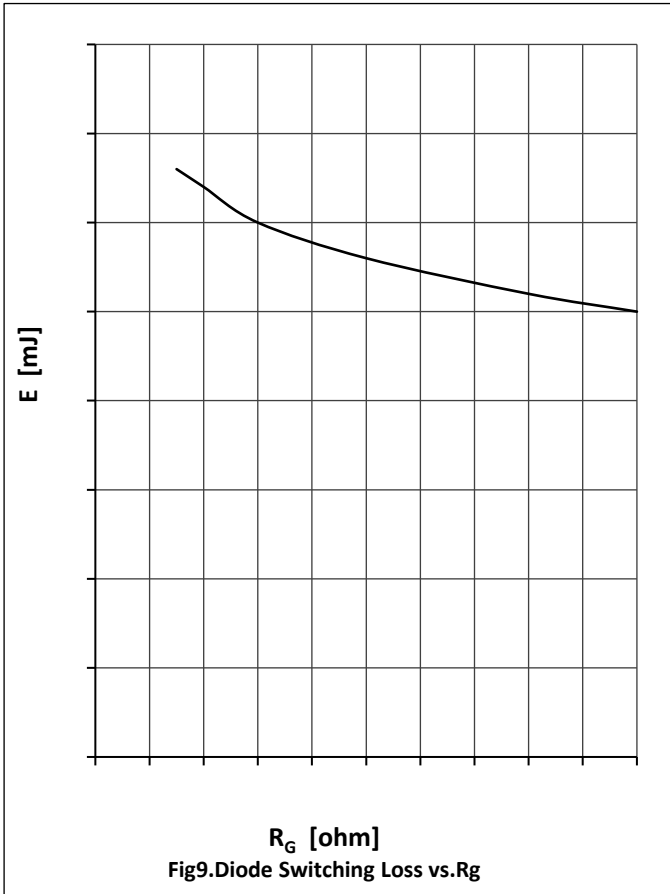



# MG50P12E2A

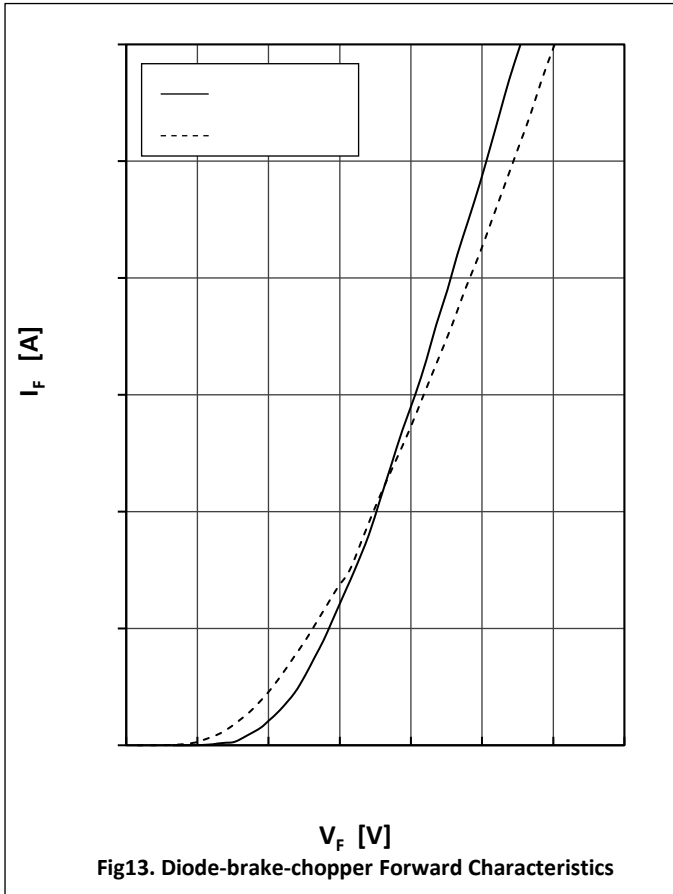



# MG50P12E2A

## ● Circuit Diagram

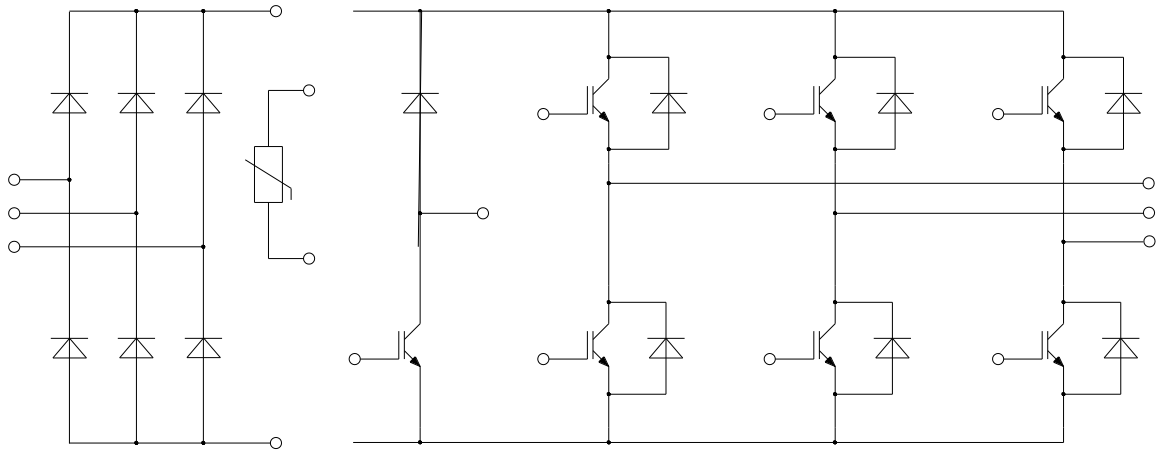

## ● Package Outline Information

Dimensions in Millimeters

